



Magswitch Technology, Inc.  
 8774 Yates Dr. Suite 140  
 Westminster, CO 80031  
 Magswitch.com.au  
 303-468-0662

# Magswitch MagMount 600

## P/N: 8100580

The Magswitch MagMount is a single lever operation switchable magnet that allows for easy movement and placement of a tool. The top mount magnets feature two magnets are ideal for supporting fixtures over a distance. The fixed bar magnet is for flat steel, the swivel bar magnet is for round or uneven shapes.

**WARNING!**  
**Do Not Operate Unless In Contact With Ferrous Target**

SPECIFICATIONS	
<b>P/N: 810580 - MAGSWITCH MagMount 600</b>	
Max Breakaway*	600 lbs/272 kg
Full Saturation Thickness	3/8" / 10 mm
2:1 Shear Working Load*	61 lbs/ 27 kg
Net Weight	3.3 lbs/1.5 kg
Overall Height	72 mm
Magnetic Pole Footprint	75mm x 51.5 mm

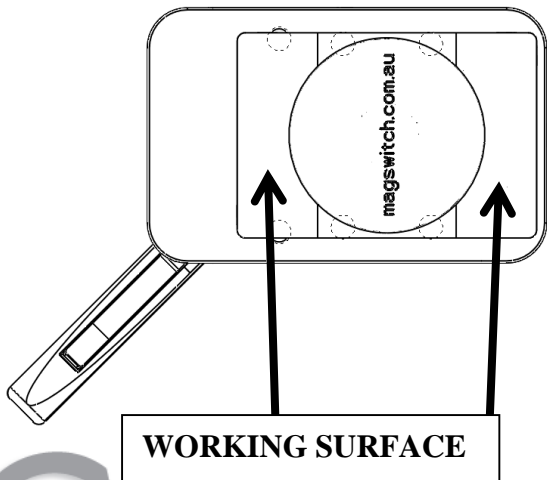

Part Number 110692  
 Revision Date: June 26, 2012

\* Max Breakaway determined in laboratory environment on 2" thick SAE1018 Steel with surface roughness 63 micro inches. Many factors contribute to the actual breakaway force in each application. Always test the magswitch in each application before deployment. Refer to the magswitch information booklet for more information.

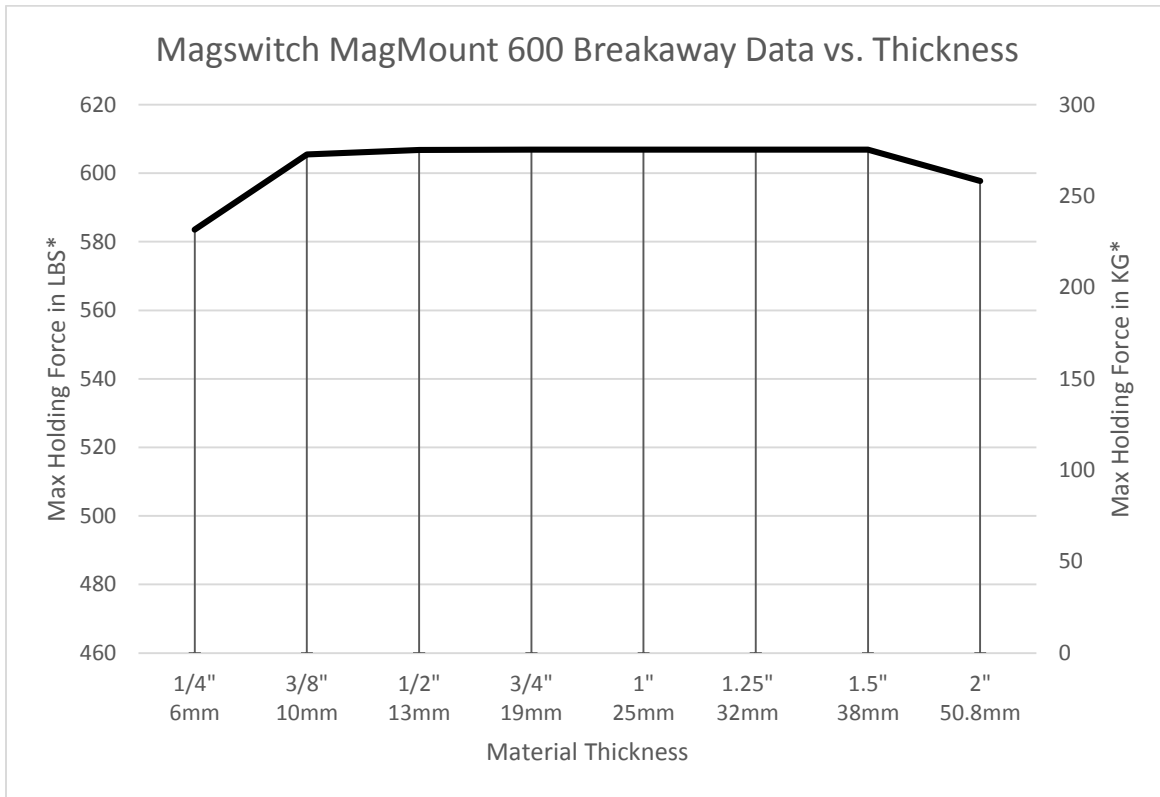

Part Number 110692  
 Revision Date: June 26, 2012

1 2 3 4 5 6

A

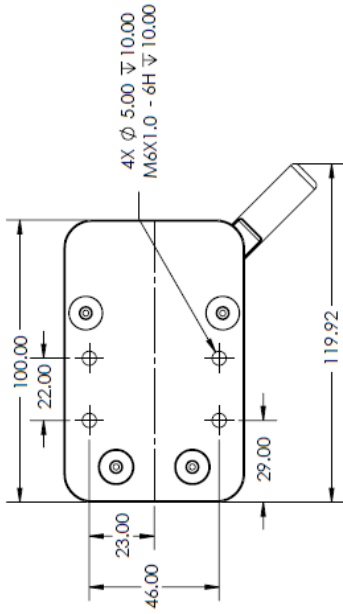

B

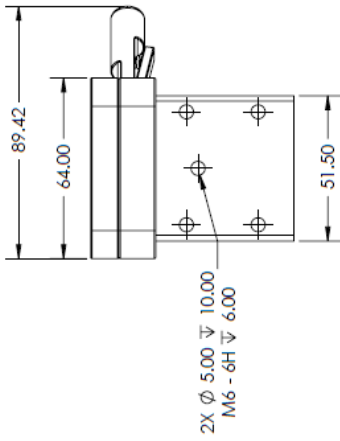

C

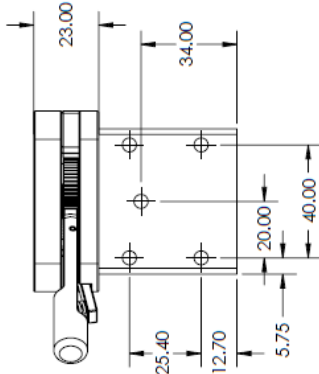

D

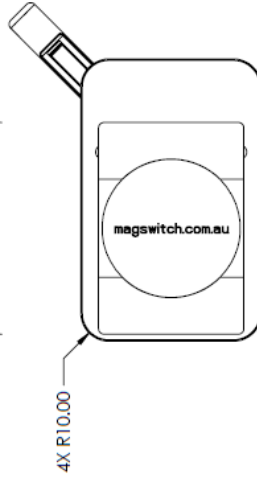

THIS DOCUMENT, AND THE INFORMATION IT CONTAINS, INCLUDING THE PRINCIPLES OF MAGSWITCH TECHNOLOGY, IS CONFIDENTIAL AND IS NOT TO BE REPRODUCED, COPIED, OR LOANED IN PART OR IN WHOLE. THE INFORMATION IS TO BE RELAYED TO ANY OTHER INDIVIDUAL OR COMPANY WITHOUT THE WRITTEN ACCEPTANCE OF THIS DOCUMENT CONSTITUTES AN AGREEMENT TO THESE RESTRICTIONS.

INTERNATIONAL DRAWING PRACTICE  
ISO 25669  
DIMENSIONS IN MILLIMETERS  
THIRD ANGLE PROJECTION  
DO NOT SCALE

DATE: 4/26/2013  
DRAWN: Y. Yan  
DESIGN: Y. Yan  
REV. CHECK: Y. Yan  
APP. CHECK: Y. Yan  
DATE: Y. Yan  
DATE: Y. Yan  
DATE: Y. Yan  
DATE: Y. Yan  
DATE: Y. Yan  
DATE: Y. Yan

**magswitch**  
8774 YATES DRIVE, SUITE 140  
WESTMINSTER, COLORADO 80031  
303-468-0662 / FAX 303-951-9918

**MagMount 600**

SIZE: B  
CAGE CODE: 8000580  
DWG. NO.: 8000580  
REV: 01

SCALE: 2:3  
WEIGHT: 1.697.07 g

1 2 3 4 5 6

A

B

C

D



Part Number 110692  
Revision Date: June 26, 2012